

1. GAS VENT DESIGNATIONS/TYPES OF APPLIANCES

Selkirk Canada Corporation Type B Gas Vent parts LISTED and produced under the Factory Inspection and Follow-up program of Underwriters' Laboratories, Inc. carry the LISTING MARK illustrated here. Type B Gas Vent has been tested, and listed using all of the supports, firestop, etc., described herein. Deletion or modification of any of the required parts or materials may seriously impair the safety of your installation, and void the certification and or warranty of this vent. It is of the utmost importance that this vent be installed only in accordance with these instructions.

Type B Gas Vent is designed for venting of listed (L.P. or Natural) gas appliances equipped with draft hoods and other listed gas appliances specified for use with Type B gas vent producing flue gas temperatures not in excess of 245°C (470°F). DO NOT USE Type B Gas Vent for Category II, III or IV gas appliances, or for any gas appliance which requires either a pressure-tight or liquid-tight venting system.

All sizes of Selkirk Type B Gas Vent may be used in single and multistory buildings. All Type B Gas Vents may be used for both individual and multiple appliance venting.

Selkirk Type B Gas Vents are to be installed and used in accordance with the Canadian Fuel Gas Installation Code CSA-B149.1-00, the National Fuel Gas Code NFPA 54, the Standard for Chimneys, Fireplace and Venting Systems NFPA 211, the "International Fuel Gas Code" and/or applicable local/regional codes.

CAUTION: WEAR GLOVES WHILE HANDLING METAL PARTS TO AVOID PERSONAL INJURY. SHARP EDGES OR PROJECTIONS CAN CUT YOU.

2. GENERAL

Before beginning installation be sure that the overall height and Gas Vent size conform to building code requirements. Use Selkirk Gas Vent and Chimney Sizing Handbook or the Fuel Gas Codes to select the correct Gas Vent diameter. Avoid using a larger than necessary vent diameter.

Situate the Gas Vent in the structure so that it can be installed without cutting joists, sill plates or major load bearing partitions or members. It is also important to locate the base of the Gas Vent as near as possible to the heating appliance.

Selkirk Type B Gas Vent must be installed with 25mm (1") minimum air space clearance to combustibles. Where the Gas Vent extends through inhabited spaces, it must be enclosed with 25mm (1") clearance to avoid personal contact and damage. These clearances are marked on all gas carrying items and they apply whether they are horizontal or vertical, or pass through floors, walls, roofs or framed spaces. The appropriate clearance should be observed to joists, studs, subfloors, plywood, drywall, or plaster enclosures, insulating sheathing, rafters, roofing, and any other materials classed as combustible. Enclosure material should have a fire resistance rating at least equal to that of adjacent floor or ceiling material. Keep electrical wires and building insulation away and out of the required air space.

A NOTICE SHOULD BE POSTED near the point where the Gas Vent is connected to the appliance, with the following wording: "Connect this Gas Vent only to gas burning appliances, as indicated in the installation instructions and do not connect to incinerators, or liquid or solid fuel burning appliances". A reminder also to homeowners to check the rain cap for icing during low ambient temperatures.

3. GAS VENT JOINT METHOD

All joints in Selkirk Type B Gas Vent must be secured using the "Snap Lock" feature. To use the Snap Lock feature, orient sections as shown in Fig.1 and force adjacent piece together until a "SNAP" is heard, indicating full/proper joint engagement. NOTE: Some local jurisdictions require a supplemental screw(s) at joints to prevent disengagement of the joint. Although

Round Type B Gas Vent Model RV

INSTALLATION INSTRUCTIONS

WARNING

Failure to follow the installation instructions could cause FIRE, CARBON MONOXIDE POISONING, OR DEATH. If you are unsure of installation requirements, call the Phone Number listed on the instructions, 1-800-267-8178 or visit www.selkirkcanada.com.

not required under the terms of the UL Listing because of the integral couplers, screws are permitted to be installed at the joints in 3" through 8" vent. In such case, the screws should be located approx. 1/4" from overlapped edge and must be maximum 1/4" in length so they do not pierce or deform the inner liner. A new Lock-Tab® feature provides the equivalent of using a screw for this purpose since, once engaged (with finger or thumb until it bends into the groove in the top/outlet end of the adjacent piece), it prevents the pipes from being disengaged unless the tab is pried back out and dimples aligned.

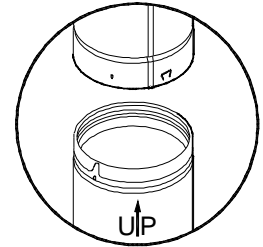

FIG. 1 3" - 8" RV

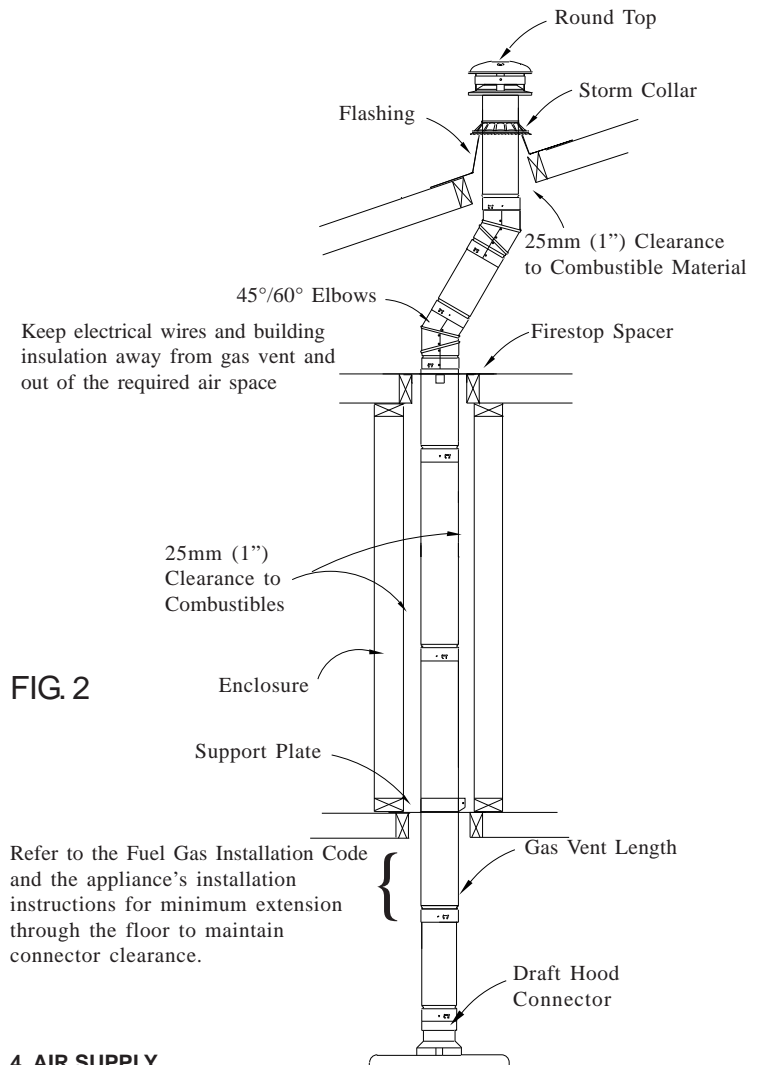

FIG. 2

4. AIR SUPPLY

Gas appliances must have an adequate air supply for combustion, vent operation, and ventilation. Special provisions for bringing in outside air may be necessary in tight buildings or when appliances are in small rooms. Consult

the Canadian Fuel Gas Code CSA-B149.1-00, the National Fuel Gas Code NFPA 54, and/ or local building codes for air supply requirements.

5. VENT CONNECTOR TYPE AND SIZE

Selkirk Gas Vent pipe meets all building code and safety standards for use as gas appliance vent connectors. Correct selection of connector and vent size is detailed in the Selkirk Gas Vent and Chimney Sizing Handbook, the Installation Gas Code CSA-B149.1-00, the National Fuel Gas Code NFPA 54, and local/ regional codes.

Draft hood connectors must be attached to the appliance outlet with screws. Single wall connectors, if used must be secured to the appliance, to the gas vent, and at all joints with 3 sheet metal screws per joint. Attachment of vent to non-metallic outlets should be per appliance manufacturer recommendations.

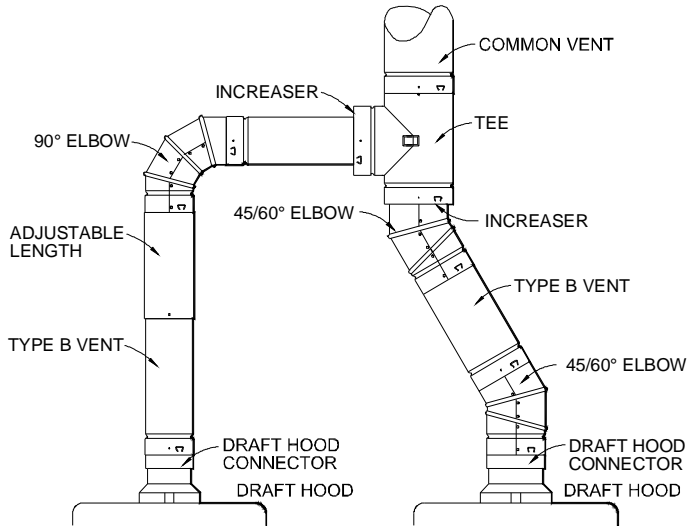

FIG. 3

6. VENT LOCATION AND ENCLOSURES

SELKIRK TYPE B GAS VENTS ARE RECOMMENDED TO BE INSTALLED WITHIN THE HEATED PORTION OF THE STRUCTURE WHENEVER POSSIBLE TO REDUCE HEAT LOSS WHICH MAY IN TURN LEAD TO POOR DRAFT AND/ OR CONDENSATION/ ICING PROBLEMS.

If an exterior location is necessary, Selkirk Type B Gas Vent must be:

- Enclosed by a chase spaced out 2" from the vent at least to the roof line.
- The enclosure should be caulked to prevent entry of moisture.
- It is also recommended that the chase be insulated up to a maximum of R-12 (RSI 2.1).
- Exposed insulation shall be of the rigid type. Non rigid type must be supported so that the insulation does not come in contact with the vent.
- The bottom of the enclosure must be closed off.
- It is recommended to provide an access panel for future inspection and cleaning.

Appliances served by an exterior gas vent must have an air supply to the appliance room adequate to balance indoor and outdoor pressures. Otherwise, "stack action" of the heated building can cause reverse venting action when the appliance is off, or operating on its pilot.

In multi-family residential, high rise and many other types of buildings, codes specify that vents must be located in fire-rated shafts or chases. Building code requirements in such cases must be carefully followed with respect to wall construction, access, clearance, support, initial penetration of breaching, and method of termination.

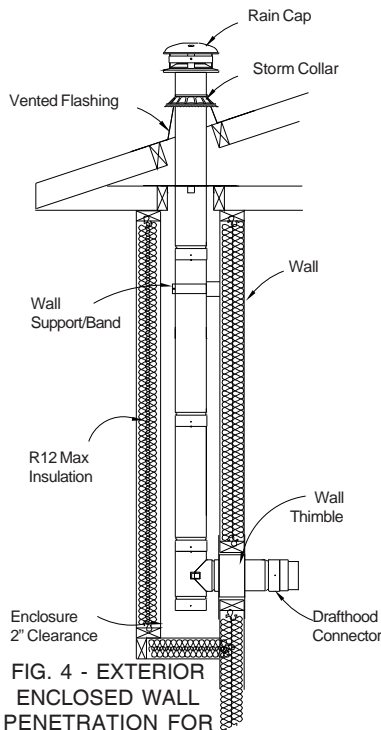

FIG. 4 - EXTERIOR ENCLOSED WALL PENETRATION FOR TYPE B

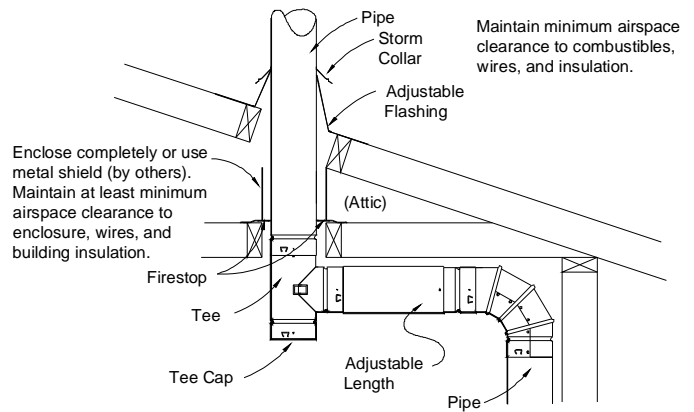

FIG. 5 - TYPICAL CEILING AND ROOF PENETRATIONS

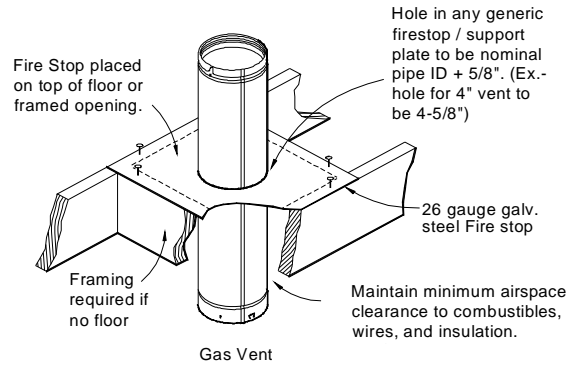

FIG. 6 FIRE STOPPING REQUIRED FOR ALL CEILING/FLOOR PENETRATIONS

7. FIRE STOPPING

All Type B Gas Vents passing through floors, ceilings or walls must be firestopped using 26 gauge or heavier galvanized steel. (See Fig. 5 and 6) The fire stop must close the area between the outer wall of the pipe and the opening in the structure. In areas such as attics with no floor, the fire stop should be placed on top of a properly framed opening. KEEP WIRES AND INSULATION OUT OF REQUIRED AIR SPACE AROUND GAS VENT.

Fire stops may be used as vent pipe supports. See Section 10. For gas vents within a shaft or chase, firestopping is provided by the vertical walls of the shaft. Any openings in the chase/ shaft below the roof must be firestopped.

8. USE OF GAS VENT FITTINGS (See Figs. 3 & 7.)

Do not cut gas vent pipe or fittings. Adjustable lengths are telescoped over fixed lengths, to accommodate odd distances between vent lengths or connectors. An adjustable length suspended below a support serves as an expansion joint between two fixed points of properly supported gas vent. Ordinarily, the adjustable length must be secured, but for expansion joints it should just maintain good contact and a minimum 1-1/2" overlap. DO NOT USE adjustable lengths to suspend any weight of pipe below.

Model RV Elbows are fully adjustable.

Selkirk tees, elbows, increasers, and short lengths are specially designed to facilitate interconnections.

Tees used to start vertical vents must use a tee cap to prevent air leakage. All unused openings in a gas vent must be sealed to prevent loss of effective vent action.

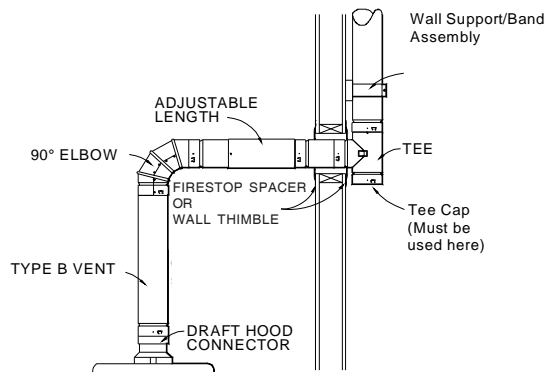

FIG. 7 - INTERIOR WALL PENETRATION FOR TYPE B

9. MINIMUM GAS VENT HEIGHT

A minimum gas vent height of 5 feet above the appliance draft hood is required. Where the vent has an offset, or serves multiple appliances, greater heights may be required for proper venting. Special care must be taken with short gas vents on duct furnaces, unit heaters, and furnaces in attics to assure they have sufficient vent height to assure complete venting. Refer to appliance manufacturer instructions and local codes for required minimum heights.

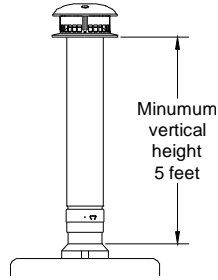

FIG. 8 - MINIMUM VERTICAL HEIGHT

10. SUPPORT - PRIMARY AND OFFSETS

Gas vent piping must be securely supported. Lateral runs are to be supported at least every 5 feet. The Support Plate has been tested to support a maximum of 10 m (35') of Gas Vent; if additional height is required, use another Support Plate on another floor level. Vertical runs firestopped at 8 to 10 foot intervals need only be supported near the bottom.

Cut away and frame a four sided opening in the floor from which the Gas Vent shall be supported, to provide 25mm (1") minimum clearance to combustibles.

Nail Support Plate securely to joist and framing members using 4 x 1-1/2" long nails (1 nail at each corner).

Insert the first length from above through the Band and the opening to achieve the required amount of Gas Vent below the Support Plate. Secure clamping band to the length with tabs and 1/4" screws (provided) so weight of vent

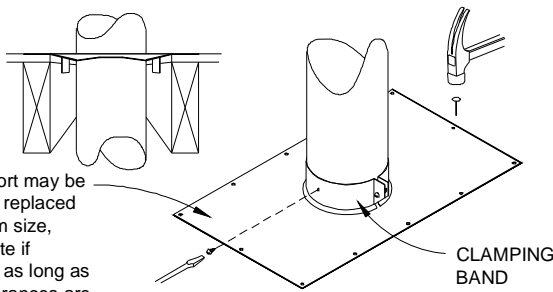

Plate support may be trimmed or replaced with custom size, generic plate if necessary, as long as proper clearances are established and maintained.

FIG. 9 FIRESTOP/SUPPORT ASSEMBLY

rests on plate. Room should be left for the draft hood connector and adjustable length.

Additional Gas Vent Lengths above the Support are simply stacked on. See joining section to secure lengths together.

Insure 1" minimum airspace is established and maintained.

Should an offset be required use a CF roof support or a support plate to support the vent above the offset. Offsets can be a maximum of 60 degrees and may take place in the attic.

Plumbers strap may be used to support both horizontal and vertical piping. All gas vents extending above the roof more than 5 feet must be securely guyed or braced.

11. FLASHING

The roof opening should be located and sized such that the vent is vertical and has the required air space clearance. The Tall Cone Flashing is for flat roofs only. It is nailed in place through all four sides of the base flange. The Adjustable Roof Flashing is positioned with the lower portion of the base flange over roofing material and the upper portion of the base flange under the roofing material. Nail through only the upper portion and sides of the base flange. (DO NOT nail through lower flange.) Use nails with a neoprene washer, or cover the nail heads with a silicone sealant. Finish roofing around the flashing, covering the sides and upper areas of the flange with roofing material. See Figures 10-A & B.

12. VENT TERMINATION

Gas vent piping must extend through the flashing to a height above the roof determined by Rules shown below. A storm collar is installed on the vent pipe over the opening between pipe and flashing. Silicone sealant is used over the joint between pipe and storm collar. Install a Selkirk Round Top to keep out rain and snow.

If the gas vent extending more than 1.25m (4') above the roof additional lateral support is required such as a Selkirk Roof Brace Kit.

Rule 1:

The top is suitable for installation on listed gas vents terminating a sufficient distance from the roof so that no discharge opening is less than 2 feet

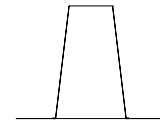

FIG. 10-A TALL CONE FLASHING FOR FLAT ROOFS ONLY

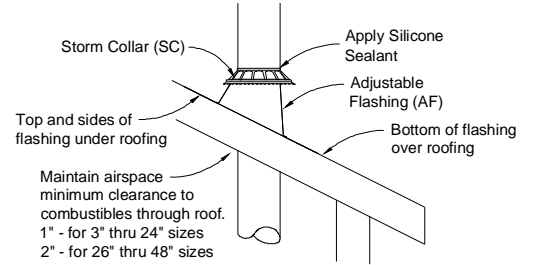

FIG. 10-B ELEMENTS FOR PROPER ROOF FLASHING INSTALLATION

horizontally from the roof surface, and the lowest discharge opening will be no closer than the minimum height specified in Fig. 11-B. These minimum heights may be used provided that the vent is not less than 8 feet from any vertical wall.

Rule II - Tops for gas vent sizes 14" and larger.

For installations other than covered by the table (Fig. 11-B), or closer than 8 feet to any vertical wall, the top shall be not less than 2 feet above the highest point where the vent passes through the roof and at least 2 feet higher than any portion of a building within 10 feet.

These rules were established on the basis of tests conducted in accordance with American National Standard ANSI/UL 441.

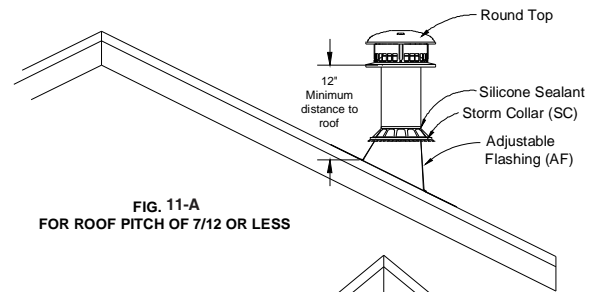

FIG. 11-A FOR ROOF PITCH OF 7/12 OR LESS

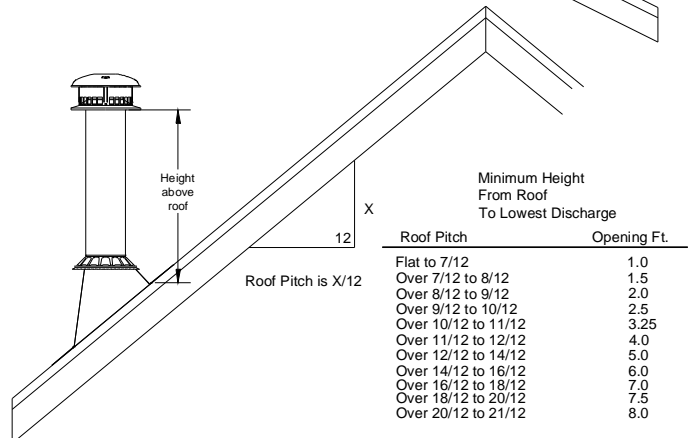

FIG. 11-B LOCATION RULES FOR FLAT TO 21/12 PITCH

13. 3"-8" TOP INSTALLATION

Selkirk Round tops (for pipe sizes 3"-8") have a spring clip which engages and locks automatically when the top is pushed into the upper end of the pipe. The top will also fit any single wall metal pipe having full nominal inch dimensions. (Never use single wall metal pipe where Type B Gas Vent is required). To attach securely, bend a one inch length of the pipe upper end inward about 1/8". The spring clip will lock under this bent edge. To remove the top from any pipe, pull up evenly on opposite sides of the skirt of the top.

15. CHECKING VENT OPERATION

Complete all gas piping, electrical, and vent connections. After adjusting the appliance and lighting the main burner, allow a couple of minutes for warm-up. Hold a lighted match just under the rim of the draft hood relief opening (see Fig. 12). Proper venting will draw the flame toward or into the draft hood. Improper venting, indicated by escape or spillage of burned gas, will cause match to flicker or go out. Smoke from a cigarette will also be pulled into the draft hood if the vent is drawing properly and flow away if not.

For fan assisted appliances, which have no draft hood, no such check is available. However, fan assisted appliances are designed to shut down if excessive pressure is detected at the outlet. If this occurs it may be an indication that the system is not venting properly.

16. PAINTING

To prolong the life and appearance of the galvanized steel outer casing and other parts of Selkirk Gas Vents located outdoors, use proper painting procedure at time of installation. Remove oil and dirt with a solvent. Paint first with a good quality zinc primer or other primer recommended for use on galvanized steel. Next apply an appropriate finish coat. Ordinary house paints applied directly to galvanized steel may not adhere well and do not prevent underfilm corrosion which leads to paint loosening and peeling.

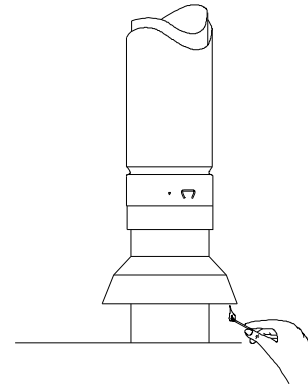

FIG.12
MATCH TEST FOR SPILLAGE

These instructions should be observed when installing Selkirk Gas Vents. Engineering methods for design and sizing of all Selkirk Gas Vents are provided in the "Selkirk Gas Vent and Chimney Sizing Handbook". Following these methods will assure safe and complete removal of combustion products.

INSTALLATION INFORMATION

Keep in a safe place for future reference

CHIMNEY MODEL: _____

TYPE OF APPLIANCE: _____

INSTALLATION DATE: _____

DESCRIPTION OF INSTALLATION (Chimney and Flue Pipe Configuration)

PURCHASED FROM:

DEALER NAME: _____

Address: _____

City: _____

Province: _____

INSTALLED BY:

TECHNICIAN NAME: _____

Address: _____

City: _____

Province: _____

PRODUCT REGISTRATION

Please register your Chimney with the Manufacturer.

Register Online:
info@selkirkcanada.com

Name: _____

Address: _____

City: _____

Province: _____ Postal Code: _____

Chimney Model: _____ Installation Date: _____

Technician Name: _____

Address: _____